

Pro 100



NewTec
Design : Audio

Pro 100







– a new dimension of sound

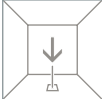

The combination of a novel aluminium membrane and a resonant body made of Corian® achieves a well-balanced, impressive performance across the entire sound repertoire at any volume level.

The soft sound characteristics create a pleasant, comfortable atmosphere from smooth background music up to a powerful high-end reproduction of stereo recordings with outstanding presence.

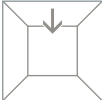
At a glance

Operating principle	Two way satellite loud speaker Uniform 360° sound dispersion	 
Features	Unique design, variable colors High-quality material – Corian® Available as floor standing, wall mounted, pendant or tabletop system Excellent voice clarity	 
Applications	Excellent sound quality ranging from smooth background music up to the high-end reproduction of stereo recordings Suitable for restaurants and bars as well as for conference rooms, showrooms and home entertainment	 

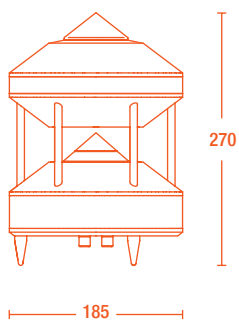

Pro 100

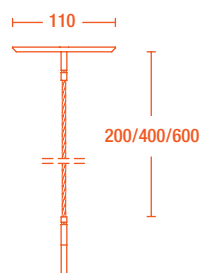

Ceiling mount assembly

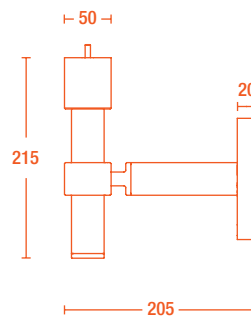

Wall bracket

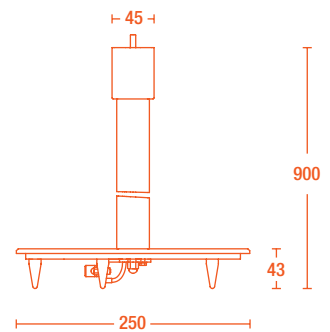

Floor stand

Application areas

Sound redefines the perception of space.

Quality acoustics promote our sense of well being and may extend the time we spend in shops, bars, restaurants and customer-oriented locations or in the wellness areas.

The conical geometry of the Pro 100 produces a uniform dispersion of sound, but conceals its source. A pleasant, brilliant sound fingerprint is created through the use of an aluminium membrane. The material used, Corian®, as well as the special design with the conical membrane and the tweeter facing it achieve full sound quality with minimum space requirements and allow a vast variety of applications.

The Pro 100 is suitable for all application areas from home theater with unique acoustics to high-grade stereo reproduction and disco music. Various accessories such as a floor stand, a wall bracket or a ceiling mount assembly ensure flexible handling.

References

Home theater, catering, music events

Fitness area of Hotel Adler Thermae, Tuscany

Entrance area of BMW Pavillon Showroom, Berlin



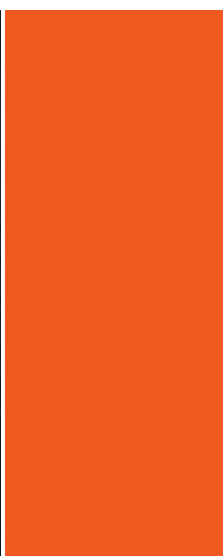
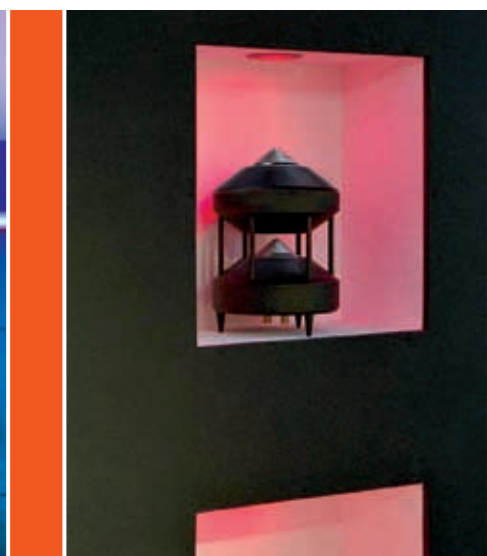
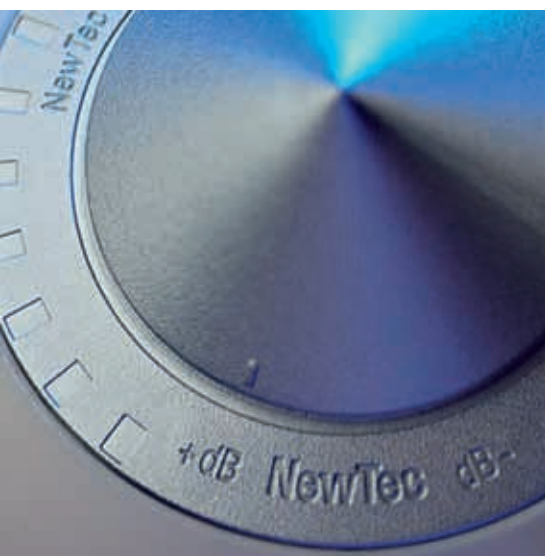

Technical Data Specifications

Name	Pro 100
Type	Two way satellite loud speaker for powerful HiFi sound
Principle	Broadband 2 way unit with active radial sound over the entire frequency spectrum
Overall dimensions W x L x H (in sight)	Ø 185 mm x 270 mm
Weight	4.5 kg
Enclosure design	Self-supporting
Enclosure material	Corian / Aluminium, wet-on-wet process
Colors	Silver, white, anthracite – All RAL colors on request
Equipment	1 NewTec M13 – 8633 by Scanspeak 1 dome tweeter D2010 by Scanspeak
Treble adjustment	L-pad control infinitely variable on top side
Impedance	8 Ω
Magnetic shielding	Not provided
Rated / Power capacity	100 W RMS / 180 W
Membrane material	Aluminium / soft dome
Max. NewTec membrane hub	5 mm
Sensitivity (1 W, 1 m)	83.5 dB (+6 dB / 360°)
Maximum SPL with high-pass filter	107 dB (active high pass 120 Hz / 18 dB - octave)
Crossover frequency	5800 Hz (6dB - oct. Butterworth)
Frequency response	125 - 20 000 Hz (+/-3 dB)
Connectors	Screw terminals (0 - 10 mm²) brass 24K gold plated, red / black marking
Installation options	Floor standing, wall mounted, tabletop or pending loud speaker
Accessories	NewTec: Floor stand, wall bracket, ceiling mount assembly





Product Overview

The Cono Linie

-  Cono alto
-  Cono pendo
-  Cono solo
-  Cono duo

The Cono Linie with integrated light

-  Cono solo Lux
Cono solo LED
-  Cono modulo

The Pro Linie

-  Pro 100
-  Pro 200
-  Pro 400

“We converge sound with form.”

NewTec
Design : Audio

Negrellistrasse 13B
I – 39100 Bolzano, Italy
Tel +39 0471 058 065
Fax +39 0471 058 066

info@newtec-audio.com
www.newtec-audio.com